

33.SERIE ML

SERIE ML - Motores Monofásicos de carcasa de aluminio con arranque reforzado

Valores eléctricos (50Hz) – 2 Polos

Tamaño de carcasa	Potencia (kW)	Corriente (A)	RPM	Rend (%)	(Cosφ)	Par nominal (N·m)	Ms/ Mn**	Mmax/ Mn	Intensidad de arranque	Condensador funcionamiento (μFV)	Condensador de arranque (μFV)	dB(A)	Peso* (kg)
-------------------	---------------	---------------	-----	----------	--------	-------------------	----------	----------	------------------------	----------------------------------	-------------------------------	-------	------------

ML631-2	0.18	1.38	2710	63	0.9	0.63	2.5	1.6	8	10μF/450V	30μF/250V	70	3.9
ML632-2	0.25	1.89	2710	64	0.9	0.88	2.5	1.6	10	12μF/450V	40μF/250V	73	4.4
ML711-2	0.37	2.66	2780	65	0.93	1.27	2.5	1.8	15	12μF/450V	75μF/250V	75	6.1
ML712-2	0.55	3.78	2790	68	0.93	1.88	2.5	1.8	20	16μF/450V	100μF/250V	76	7
ML801-2	0.75	4.87	2800	72	0.93	2.56	2.5	1.8	30	20μF/450V	100μF/250V	76	9
ML802-2	1.1	7.04	2810	73	0.93	3.74	2.5	1.8	40	30μF/450V	150μF/250V	79	10.3
ML90S-2	1.5	9.48	2810	74	0.93	5.10	2.5	1.8	55	40μF/450V	200μF/300V	84	16.3
ML90L-2	2.2	13.57	2810	75	0.94	7.48	2.5	1.8	75	50μF/450V	250μF/300V	84	16.7
ML100L-2	3.0	17.83	2830	77	0.95	10.13	2.5	1.7	110	60μF/450V	400μF/300V	88	25
ML112M1-2	3.7	21.48	2850	78	0.96	12.40	2.5	1.7	140	60μF/450V	600μF/300V	90	33
ML112M2-2	4.0	22.18	2850	80	0.98	13.41	2.5	1.7	150	60μF/450V	600μF/300V	90	34.2

Valores eléctricos (50Hz) – 4 Polos

Tamaño de carcasa	Potencia (kW)	Corriente (A)	RPM	Rend (%)	(Cosφ)	Par nominal (N·m)	Ms/ Mn**	Mmax/ Mn	Intensidad de arranque	Condensador funcionamiento (μFV)	Condensador de arranque (μFV)	dB(A)	Peso* (kg)
-------------------	---------------	---------------	-----	----------	--------	-------------------	----------	----------	------------------------	----------------------------------	-------------------------------	-------	------------

ML631-4	0.12	1.05	1350	55	0.9	0.85	2.5	1.6	6	10μF/450V	30μF/250V	64	4.1
ML632-4	0.18	1.55	1350	56	0.9	1.27	2.5	1.6	8.5	12μF/450V	40μF/250V	64	4.5
ML711-4	0.25	2.01	1380	60	0.9	1.73	2.5	1.7	10	12μF/450V	50μF/250V	66	5.9
ML712-4	0.37	2.84	1380	63	0.9	2.56	2.5	1.7	15	16μF/450V	75μF/250V	68	6.9
ML801-4	0.55	4.03	1400	66	0.9	3.75	2.5	1.8	20	20μF/450V	100μF/250V	71	9.6
ML802-4	0.75	5.25	1410	69	0.9	5.08	2.5	1.8	30	25μF/450V	100μF/250V	71	10.9
ML90S-4	1.1	7.24	1410	71	0.93	7.45	2.5	1.8	40	35μF/450V	150μF/250V	74	13.8
ML90L-4	1.5	9.61	1400	73	0.93	10.24	2.5	1.8	55	40μF/450V	200μF/300V	79	16.7
ML100L-4	2.2	13.90	1430	74	0.93	14.70	2.5	1.8	75	50μF/450V	300μF/300V	79	22.8
ML100L-2-4	3	18.70	1440	75	0.93	19.91	2.5	1.8	110	60μF/450V	500μF/300V	83	28.7
ML112M1-4	3.7	21.99	1440	77	0.95	24.55	2.5	1.7	140	60μF/450V	600μF/300V	86	31
ML112M2-4	4.0	22.41	1440	80	0.97	26.54	2.5	1.7	150	60μF/450V	600μF/300V	86	32.8

*Los pesos mostrados en las tablas se corresponden a la forma constructiva B3 (patas) y B14. Para brida B5 será un 1% mayor y para B35 Y B34 un 5% mayor

**Mn es el par nominal y Ms el par de arranque

SERIE ML - Dimensiones generales y forma constructiva

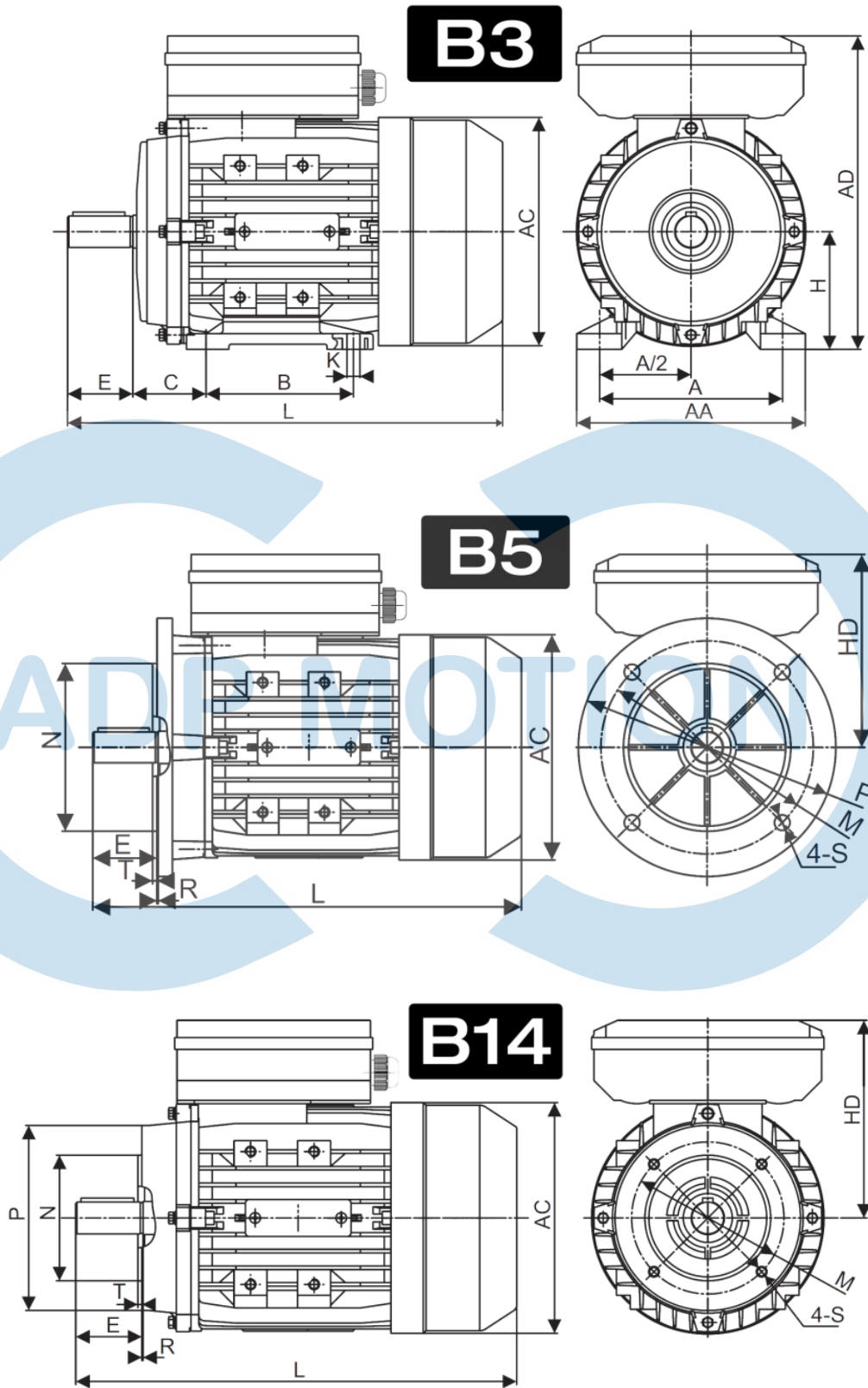

Medidas en mm

Tamaño de Carcasa	B3					B14						B5					
	A	B	C	H	K	M	N	P	R	S	T	M	N	P	R	S	T

63	100	80	40	63	7X10	75	60	90	0	M5	2.5	115	95	140	0	10	3.0
71	112	90	45	71	7X10	85	70	105	0	M6	2.5	130	110	160	0	10	3.5
80	125	100	50	80	10X13	100	80	120	0	M6	3.0	165	130	200	0	12	3.5
90S	140	100	56	90	10X13	115	95	140	0	M8	3.0	165	130	200	0	12	3.5
90L	140	125	56	90	10X13	115	95	140	0	M8	3.0	165	130	200	0	12	3.5
100L	160	140	63	100	12X15	130	110	160	0	M8	3.5	215	180	250	0	15	4.0
112M	190	140	70	112	12X15	130	110	160	0	M8	3.5	215	180	250	0	15	4.0

Tamaño de Carcasa	Dimensiones Generales					Dimensiones eje						
	AA	AC	AD	HD	L	SS	XX	ZZ	D	G	F	E

63	120	130	179	116	212	M4	10	15	11	8.5	4	23
71	132	145	194	123	255	M5	12	18	14	11	5	30
80	157	165	223	143	290	M6	16	22	19	15.5	6	40
90S	172	185	240	150	335	M8	20	25	24	20	8	50
90L	172	185	240	150	365	M8	20	25	24	20	8	50
100L	196	205	260	160	398/ 416	M10	22	28	28	24	8	60
112M	222	230	295	183	416	M10	22	28	28	24	8	60

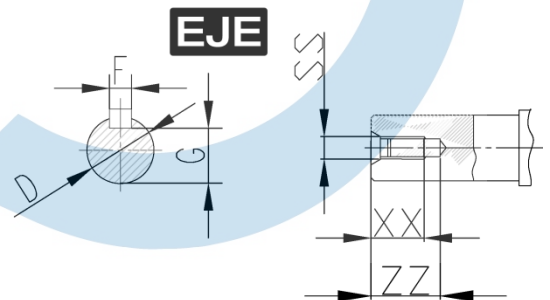

34. CONEXIÓN MOTORES MONOFÁSICOS

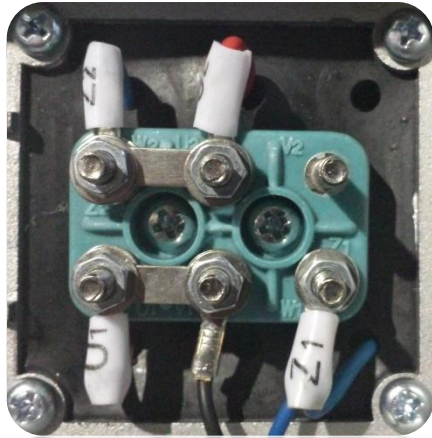

Conexión para Sentido de Giro Horario

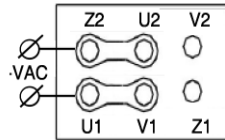

Esquema Conexión interno del Bobinado

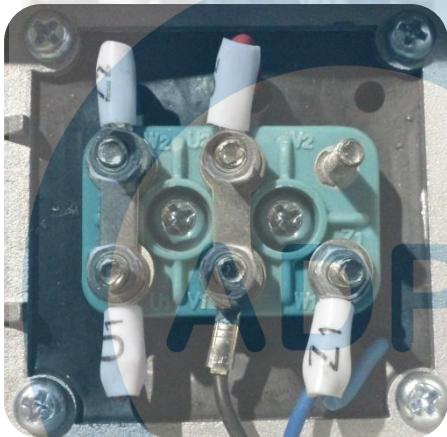
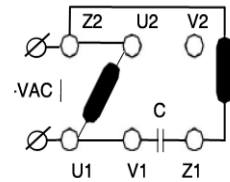

Conexión para Sentido de Giro Antihorario

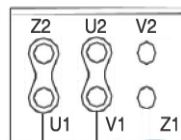

Esquema Conexión interno del Bobinado

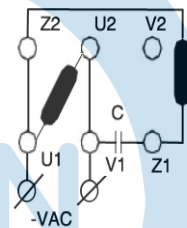

Los motores monofásicos de la serie MY tienen instalado un condensador para el arranque. La serie ML de TECHTOP tiene las mismas características pero cuentan con un condensador adicional para el arranque de par fuerte.